



Developments in Processing Hanger Technology

Richard A. Dooley

RICHARD A. DOOLEY received his B.S. degree in mechanical engineering from Notre Dame University. He is the founder and former president of AP Conveyor Corporation. He continues to be involved in equipment design, sales, and coordination of construction and installation of the firm's conveyors and other products. He holds 12 U.S. patents and foreign equivalents for spray paint robots and conveyor tooling.

Introduction

The use of the hanger-to-conveyor mounting point as an active element in the quest for line density has become accepted in the finishing industry during the past decade. Under the proper conditions of inclines and declines and a relatively flat ware package, productivity increases of 20–50% have been obtained by the Angle Pivot™ system alone. By combining out-of-plane rotation with an advanced continuous load bar design, the utility of a monorail conveyerized processing or finishing system can be enhanced in a variety of ways. When new racks or hangers are designed for these systems, several additional features may be used that have more general applicability.

Development of the Load Bar System

Initially the Angle Pivot™ linkage was built into discrete devices, which were combined with or built into the racks on a one-for-one basis. This technique is still useful under some conditions, but it was soon realized that a better and more generally applicable architecture would separate the two and make Angle Pivot™ mounting available at the highest altitude and at the shortest possible spacing increments around the entire conveyor.

Notched steel plates, suspended by S-hooks or chains from the conveyor at two points, have performed a similar function in finishing systems for many years. According to geographic area, they are variously known as load bars, flight bars or saw bars. They provide the users with some inter-trolley spacing versatility and also as a secondary benefit divide the payload weight in some proportion between two trolley wheel sets. More about this later.

Taking the load bar approach, providing equally spaced and equally useable holes, and adding in-plane thrust capability to the leading mounting point, gave a tool which combined the advantages of both and provided several others as well, even on non-Angle Pivot™ applications. Use of a standardized square tube section and mounting hole configuration, along with a variety of lengths and attachment fittings, enables the bars to be fitted to all nine varieties of monorail conveyor in common North American use (**Figure 1**).

What follows is a short itemized discussion of the advantages of the tubular Angle Pivot™ load bars over notched flat steel bars:

1. Most evident upon initial inspection is the equal spacing and equal usability of holes on 2" or 3" centers around the entire system. This is in contrast to the missing notch or hole between the ends of "saw bars" at the trolley or wheel set locations. The effect of this missing notch is to cause the hanging crews to gravitate to a pattern using even multiples of the bar spacing. Bars that overhang the suspension element on both ends also suffer because nothing can be hung on one end without a balancing part being hung simultaneously on the other end (so the bar won't "tip up").

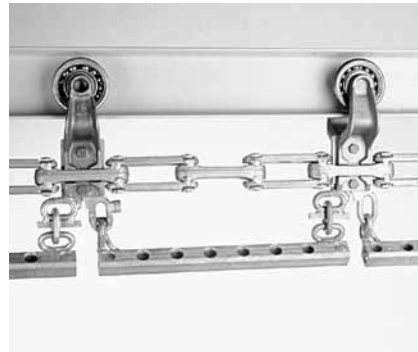

Figure 1 – Continuous load bar Angle Pivot™ installation on X-458 short-drop conveyor. Trolley spacing = 16".



Figure 2 – Single rack top going into X-348 load bar. Yaw angle is in proportion to pin axis angle down from horizontal.

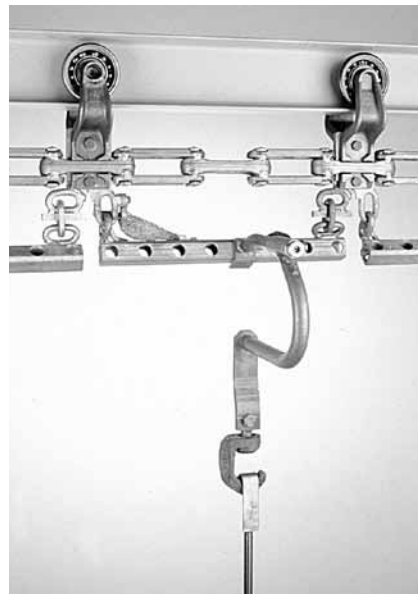

Figure 3 – Master C-hook with detachable rack. Note absence of counterweight; made possible by a rotation stop on the load bar.

2. Better yaw stability or tracking in the plane of the conveyor is gained by the long “wheelbase” of the bars and the small diametral clearance between hole I.D. and the engagement pin on the rack. Authorities on the operation of powder systems recommend $\pm 5^\circ$ as a maximum out-of-plane condition in the corona zone of the booths. With proper rack maintenance, a 30" wide part can be made to track within $\pm 1/4"$ at the edges, which corresponds to less than one degree.
3. An important but more subtle benefit is the in-plane thrust capability of the bars. They swing sideways readily but are stiff in the fore-and-aft direction. This enables double-hung parts to have the hanging hooks canted in (for minimum part tilt on inclines/declines) or out (to ease cramping together on 180° oven and takeup turns). It results in the ability to drive a rotator or unlatch a detent with no backward recoil or swinging of the racks. High mounting altitude of the bars enables them to be cleaned continuously, using the powered rotating wire brush devices supplied by many manufacturers of conveyor lubrication and maintenance equipment. This way, no removal for burnoff is ever required. And driving of a lateral tilting mechanism for air bubble burping in the tanks of electrophoretic or autophoretic painting systems is easily done.
4. By addition to each leading mount link of a simple rotation stop, the bars may be made to support a non-counterweighted C-hook. Properly applied, this saves weight on the conveyor and non-productive heat absorption in the ovens.
5. A benefit to the conveyor wheels and track which accrues from any application of load bars is that the weight of the individual hangers or racks is spread in some proportion between two wheel sets. There is an empirical load-life relationship in all rolling or sliding element bearings which says that by cutting the load on a bearing in half, the life is increased by a factor of between eight and ten. This very powerful relationship quietly and simply prolongs the life of all conveyor components in a load bar equipped system.

Tools for Use with Angle Pivot™ Load Bars

In contrast to the fairly standardized load bars, a wide variety of process hangers or racks has been employed to customize each tooling system for the individual customer's application. People unfamiliar with finishing are tempted to dismiss racks as nothing more than glorified coat hangers. In reality, there can be up to ten different design requirements imposed upon a single specimen. Frequently these conflict, and the art in designing them is knowing where to make the compromises. Controllable out-of-plane rotation is a valuable tool provided by the Angle Pivot™ technique. In this section, devices which occupy the freeboard area between conveyor and work envelope will be discussed. In the next, some useful construction features generally applicable to all racks will be presented.

Common to all Angle Pivot™ devices is an articulated linkage comprised of a tilted-axis bearing between the individual rack and the conveyor, with a second perpendicular horizontal-axis bearing parallel to the conveyor attached to it. If this sound like a Cardan U-Joint, it is. In fact one of our patents covers this, and production tools have been built using



Figure 4 – Top end of eyebar rack. Rods rotate in holes in alloy steel bar engagement fitting.

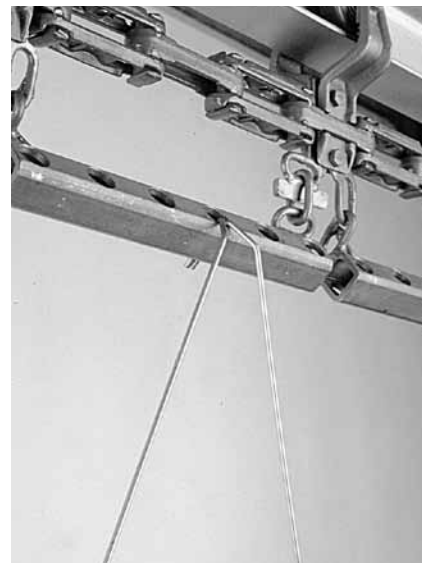

Figure 5 – Paired J-hooks with identical ends may be reversed end-for-end to double time interval between strippings.

manufactured U-Joints incorporated into discrete devices for the purpose. In the load bars the function of the second axis is hidden in the rotationally “loose” chain links on the fore and aft ends of the bar.

Tilt of the lateral axis from the horizontal (termed the “Pivot Angle”), and the incline/decline angle of the conveyor from horizontal, uniquely determine the yaw angle of the rack from the plane of the conveyor by the relationship:

$$\text{Tan Pivot Angle} = \frac{\text{Sin Yaw Angle}}{\text{Tan Incline/Decline Angle}}$$

Rotation of the second bearing or load bar, and relative angular displacement of the bar with respect to the engagement pin, are also uniquely determinable for a given set of input parameters. Thus the design of these articulated links can be done without the aid of bent paper clips, more sophisticated aircraft-type mockups, or computer programs.

An important feature of the load bars is the ability of an individual rack to “tell” the load bar how far out of plane to swing it, and how quickly. Racks with a length-to-thickness ratio down to 2.5 to 1 can benefit, and incline/decline angles of up to 60° can be negotiated with no loss in the “solid wall” of parts going through the processing steps of a system. All this is done in the freeboard area, by a simple mechanism mounted to the rack or shared between it and a master hook which interposes between it and the load bar (*Figures 2 & 3*). These are used on crossarm racks, picture frame racks, T-bars, and other workholder tools customized for individual part retention requirements.

One limitation of the T-bar as a general purpose rack is the unavoidable loss of line density which occurs when the length of the bar exceeds the width of the workpiece. This can be avoided by the use of eye bar racks and S-hooks, paired double-end J-hooks, or paired workholder hooks, which are a more sophisticated version of the latter (*Figures 4, 5 & 6*). The eyebar design is self-explanatory except that an alloy steel casting is used as a load bar engagement fitting. Paired J-hooks have the pivot angle bent into both ends and may be reversed to double the time interval between strippings.

Paired workholder hooks with co-axial engagement pins may be used in pairs as shown or singly to hang double hung long parts. They offer much more positive tracking control when used in pairs than either eye bars or paired J-hooks. A disadvantage is that on wide parts the incline/decline angle capability may be restricted.

C-hooks and sanitary pans are sometimes used for an additional increment of cleanliness in the washer-through-oven portion of a system. Angle Pivot™ load bars are located at the optimum altitude to permit the upper horizontal element of a C-hook to just clear the grease fittings on the roller turns of external chain conveyor systems. Similar clearance between load bar mounting links and the rims of turn wheels in ovens is also obtained at this altitude. Previously it was mentioned that the torque capability of the bars can be used to avoid the necessity of counterweighing the hooks. Compound linkages can also be incorporated at the load bar engagement point (*Figure 7*).

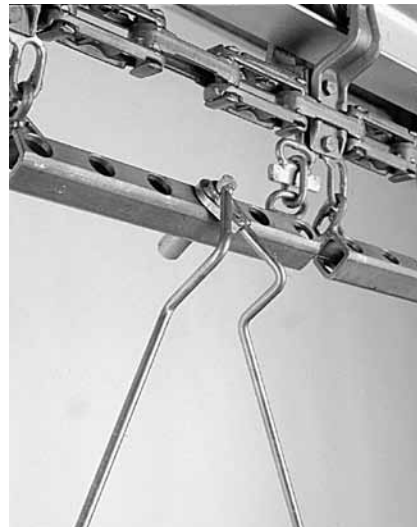

Figure 6 – Paired workholder hooks have concentric pins. Also may be used separately to double-hang long parts.

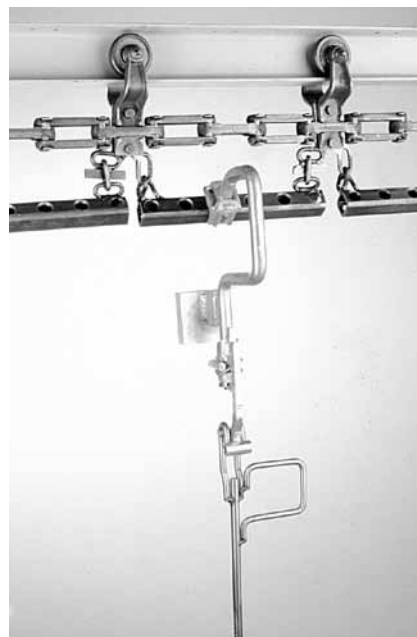

Figure 7 – Mechanism at top of C-hook is a compound Angle Pivot™ linkage. This provides 60° incline/decline angle capability without loss of “solid wall” line density.

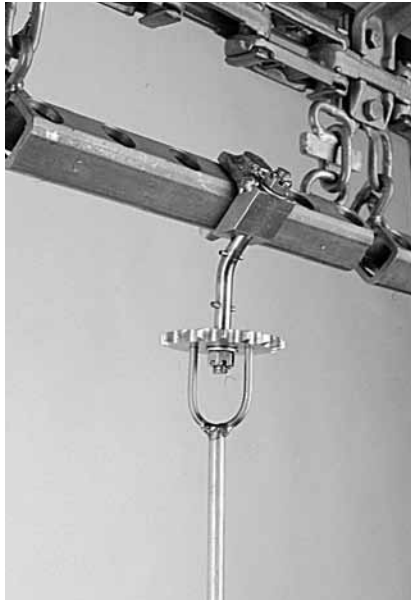

Figure 8 – Non-recoil automatic rotator. Contact point with drive gear rack is on extended centerline of Angle Pivot™ bearing.



Figure 9 – Two-position detented rotator. Bend angle of hardened washer between pins determines self-locking capability.

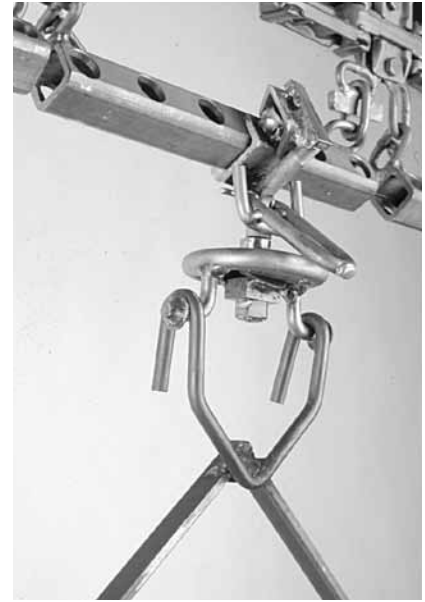

Figure 10 – Latching Rotator, with disengagement provided by lifting the latch bar with a track flanking the load/unload area.

Users of C-hook equipped systems always regard the sanitary pans as a necessary evil. Sometimes political coercion is involved, the reasoning being that if any dirt rejects are occurring and the pans are not present, that the plant personnel aren't doing everything they can to help themselves. They have great vulnerability in crashes, and must be maintained continuously. In ovens they must be vacuum-cleaned along with the rest of the oven, and in plants where less-than-perfect roof conditions exist, a small leak into the pans can run around the system and spoil an entire line of parts. Alterations to the pans may be required in an Angle Pivot™ retrofit; the most frequent being removal of the outboard rim of turn wheel-mounted pans in the ovens, and cut-back of the outboard edge in inclines and declines. There are shops which maintain very low reject rates on Class A work without the use of sanitary pans.

Rotators of several varieties are enhanced by combining them with Angle Pivot™ mounting. Automatic rotators are used to spin cylindrical parts as they pass through the corona zone of booths (**Figure 8**). Two-position detented rotators, with or without self-locking capability, permit racks to be loaded and unloaded from a single side of the conveyor (**Figure 9**). Latching rotators are used when racks must spin freely throughout the loading and unloading areas and must positively lock in the in-plane position for passage through the processing steps of the system (**Figure 10**). In all of these applications, the extended centerline of the Angle Pivot™ axis passes through the contact point between the sprocket and the actuator mechanism. Maintaining this relationship minimizes the swinging normally associated with rotation spin-up.

Hold down tracks (**Figure 11**) can be used at the unloading area only, to prevent rack disengagement from the load bar row. They are usefully combined with paired workholder hooks, where a quick upward jerk can break powder bridging between hook and work piece.

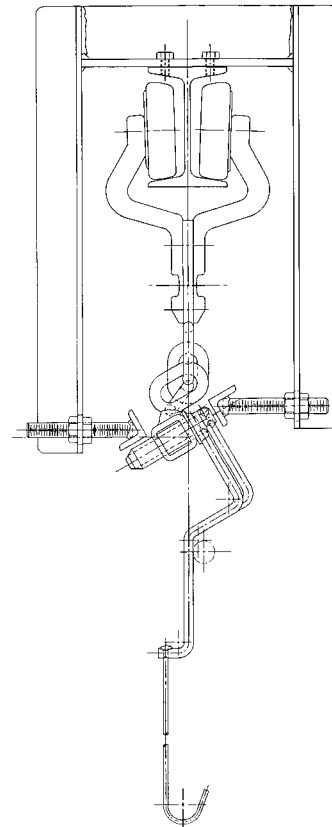

Figure 11 – Hold-Down tracks are sometimes used with paired workholder hooks (see Figure 6).

Useful Rack Construction Features

Angle Pivot™ projects sometimes include building of workholder tools (or racks or hangers, if one prefers). In doing this, we have employed some construction techniques which are of general applicability. These will be offered here, along with a short discussion of each, in no particular order of importance:

- **Diamond – T Racks*** provide the user with a means of varying the number and arrangement of hooks on a crossarm, T-bar, or picture frame rack, and to adjust these several times between rack strippings. They employ a patented square roll formed crossbar with the rack points mounted on small rectangular steel tabs (*Figure 12*). These place all relative motion surfaces into Faraday cage areas, so the bridging of cured powder, which normally would immobilize movable rack elements, does not occur. Electrical grounding is also maintained. Diamond T-racks provide the ultimate in arrangement versatility, and short pieces of the roll form are sometimes useful in providing one adjustable rack point per part on a normal weld-fabricated steel rack.
- **Quick-Disconnect Joints for Corona Zone Application** (*Figure 13*). These are fabricated of square tubing and a truncated square-section pin, and place all faying surfaces into Faraday cage areas. Even when heavily coated with cured powder, they are easy to disassemble by rapping with a hammer, or on the floor. Their primary use is on racks that are too large to fit the available stripping facilities.
- **Asymmetric Racks for Corner-Hung Rectangular Parts** (*Figure 14*) are useful when an envelope height restriction to the diagonal part dimension applies to multiple-tier racks. Part corners are staggered by row so these diagonal dimensions are not additive in establishing the envelope height.
- **Sharp Bottom J-Hooks** (*Figure 15*) are essential in a proper rack design. In contrast to a radius at the bottom of the hook, these place the edge of the hanging hole in the part in exactly the same place every time, so the part masks the grounding area of the rack point. Also this seemingly small distance across the notch restrains the parts from flapping around during powder application, which promotes a more even coating.
- **Mounting of hooks by drilled holes and TIG welding** (*Figure 15*) is a good detail. This separates the heat-affected zone of the weld from the maximum bending stress area of the hook wire. It gives a self-jigging replacement method; merely consisting of wire and weld removal with a mini-grinder. And using a TIG weld on one side of the hook wire only gives an inspectable weld, versus the plug welding with a MIG or stick welder that one is tempted to use (we have seen epidemic service failures involving the latter technique).

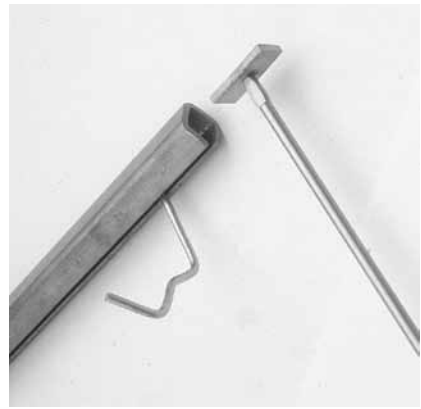

Figure 12 – Diamond-Track crossbar and hook mounting detail. This provides ultimate versatility in a general-purpose rack.



Figure 13 – Quick-disconnect joint for spray zone application. Easily disassembled after multiple coats of paint.

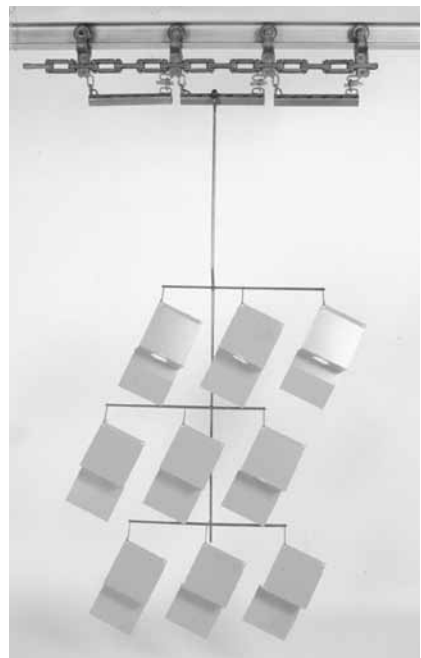

Figure 14 – Asymmetric rack with diagonal columns of parts. Saves on vertical envelope space.

*Product of Carolina Hanger Systems, Inc., Hamlet, NC

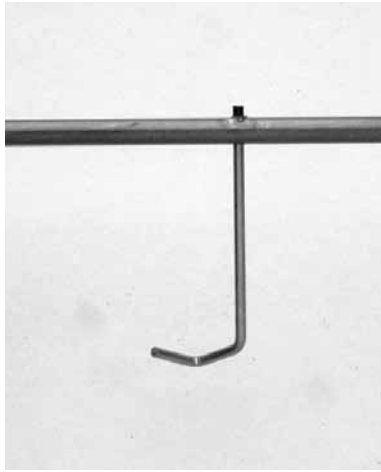

Figure 15 – Two good features of a hook: sharp bottom and TIG weld on far side of drilled mount hole.



Figure 16 – Changeable spring clip pops off like a safety pin. Useable in tube ID's and sufficiently large holes in sheet metal parts.

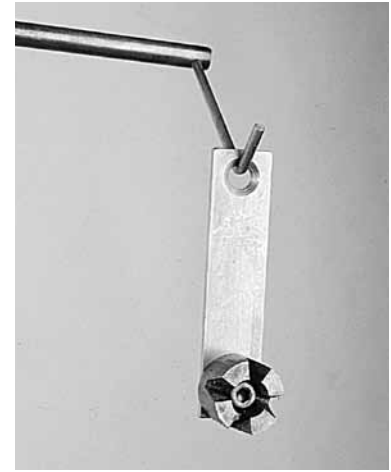

Figure 17 – Magnet tab for mounting steel parts lacking holes onto conventional rack hooks.

- **High-Temperature Materials** should always be considered when designing racks for longevity. Pyrolytic batch stripping ovens operate at a nominal 700–800°F temperature, but the racks can get hotter if any air leaks permit the fire to burn uncontrollably. Blu-Surf® ovens run at a nominal 1,300°F. Making the small parts (hooks, clips, tabs, and pins) of 302 spring stainless steel or even Inconel will lower maintenance costs and improve rack life, at a very small additional cost. Use of 304 stainless steel versus cold-rolled in the larger structural elements is advisable if any stress is imposed during the stripping process.
- **Changeable Spring Clips (Figure 16)** are useful when racking in a hole of suitable size, or on the I.D. of a tube. They are cheaply made on four-slide machines and are normally replaced after each stripping cycle.
- **Magnetic tabs (Figure 17)** permit racking steel parts designed without holes onto a conventional rack hook. They last longer if chemically stripped but can be re-magnetized without disassembly by the suppliers of the magnets, at a nominal lot charge.

Conclusions

With nearly a decade of application experience, most Angle Pivot™ tooling projects have come to use square tubular steel load bars to mount racks or individual workpieces to the conveyor. Even without articulation, these have advantages over older methods. Development of hanger tooling for these systems has likewise undergone continuous refinement toward the goals of ruggedness, ease of use, and the filling of the processing envelope with a “Solid Wall” parts.

These tools are covered by U.S. Patent Numbers 5,000,309; 5,226,525; 5,253,742; 5,303,815; and 5,566,815, plus others pending.



A Division of  **MIGHTY**HOOK

1017 N. Cicero Ave.

Chicago, IL 60651 USA

Phone: 773-378-1909

Fax: 773-378-2083

Email: info@apconveyor.com

www.apconveyor.com